

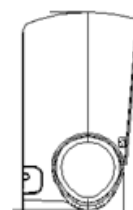

| CARACTERÍSTICAS | | |
|-------------------------------------|-------------------------------|-------------------------------|
| Modelo | MSVPBU-09HRFN1-QRD0GW | MSVPBU-12HRFN1-QRD0GW |
| Controlador | RG58E3/BGEF | RG58E3/BGEF |
| Capacidad frigorífica | 2,64 kW | 3,52 kW |
| Capacidad calorífica | 2,93 kW | 3,81 kW |
| Tuberías frigoríficas Líquido - Gas | 1/4" - 3/8" | 1/4" - 3/8" |
| Caudal de aire | 400/300/240 m ³ /h | 500/350/270 m ³ /h |
| Presión sonora | 20 dB(A) | 21 dB(A) |

| CONNEXIÓN ELÉCTRICA | | |
|---------------------|----------------------------|-----------------------|
| Modelo | MSVPBU-09HRFN1-QRD0GW | MSVPBU-12HRFN1-QRD0GW |
| Alimentación | 220-240 V / 1 fase / 50 Hz | |
| Cable Alimentación | (3+Tierra) x 2,5 mm | |

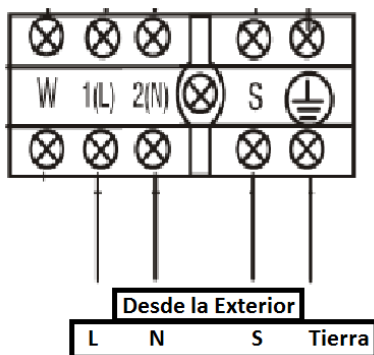

| DIMENSIONES Y PESO | | |
|--------------------|-----------------------|-----------------------|
| Modelo | MSVPBU-09HRFN1-QRD0GW | MSVPBU-12HRFN1-QRD0GW |
| Ancho | 897 | 897 |
| Alto | 312 | 312 |
| Fondo | 182 | 182 |
| Peso | 9,5 kg | 9,9 kg |