

Cassettes 600x600 & 840x840

Multisistema

FICHA PRODUCTO



RG10A1(B2S)/BGEF
Control de serie

Producto certificado por:



CARACTERÍSTICAS

Modelo	MCA3I-09HRFNX-QRDO	MCA3U-12HRFNX-QRDOW(GA)	MCA3U-18HRFNX-QRDOW(GA)	MCD1-24HRFNX-QRDOW(GA)
Capacidad frigorífica	2,63 kW	3,52 kW	5,28 kW	7,03 kW
Capacidad calorífica	2,93 kW	3,81 kW	5,57 kW	7,62 kW
Caudal de aire	450/500/580 m ³ /h	389/485/569 m ³ /h	479/584/680 m ³ /h	1.000/1.140/1.300 m ³ /h
Presión sonora	29/33/38 dB(A)	34,50/37,5/42 dB(A)	39/44/45,4 dB(A)	39,5/42,5/45,5 dB(A)
Alimentación	220-240 V / 1 / 50 Hz			
Cableado comunicación	(3+T)x2,50 mm ²	(3+T)x2,50 mm ²	(3+T)x2,50 mm ²	(3+T)x2,50 mm ²
Tuberías frigoríficas	Ø1/4" / Ø3/8"	Ø1/4" / Ø3/8"	Ø1/4" / Ø1/2"	Ø3/8" / Ø5/8"

ESQUEMA CONEXIONES

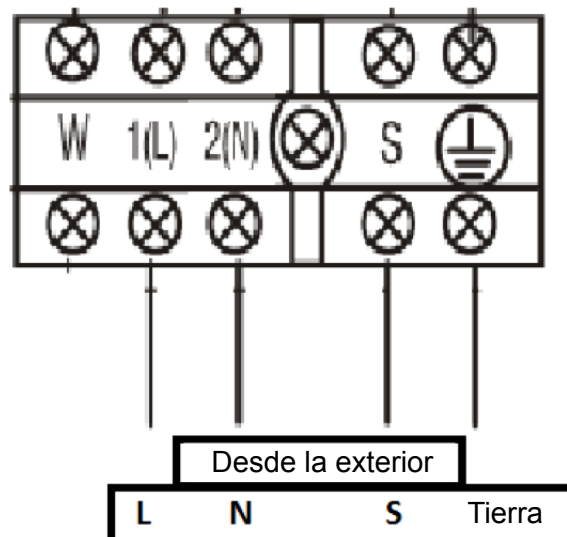

NOTAS:
 (1) Los datos y especificaciones presentes en esta ficha pueden variar sin previo aviso.
 (2) Las imágenes de esta ficha son de carácter orientativo, pudiendo ser diferentes a la máquina final.

DIMENSIONES Y PESO UNIDAD INTERIOR

Modelo	Peso
MCA3I-09HRFNX-QRDO	14,70 kg
MCA3U-12HRFNX-QRDOW(GA)	16,30 kg
MCA3U-18HRFNX-QRDOW(GA)	16 kg

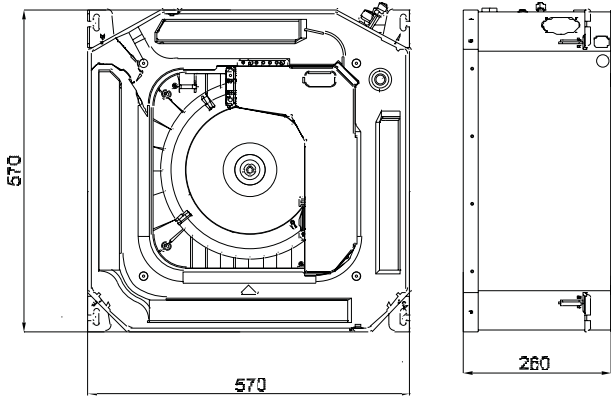

Modelo	Peso
MCD1-24HRFNX-QRDOW(GA)	21,60 kg

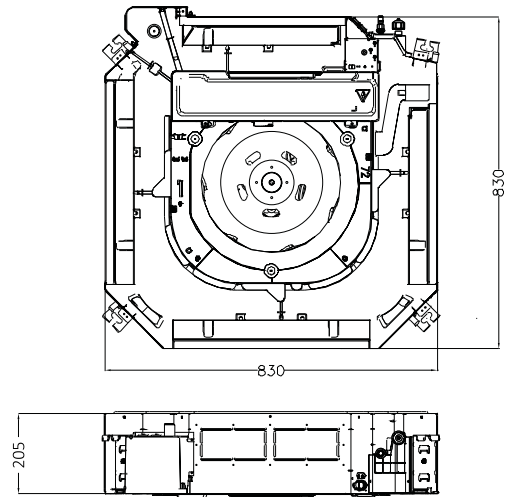

DIMENSIONES Y PESO PANEL

Modelo	Peso
T-MBQ4-03E	2,50 kg

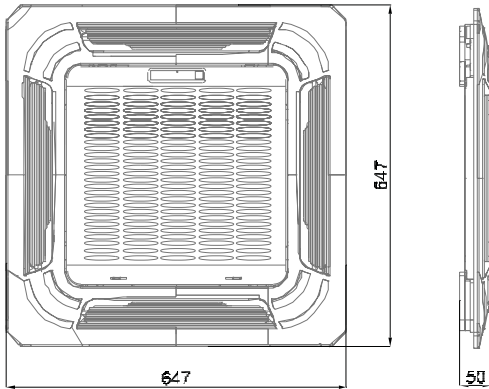

Modelo	Peso
T-MBQ4-04A1	6 kg

