

Midea Xtreme Save Series

Multisistema

FICHA PRODUCTO



RG10A1(B2S)/BGEF
Control de serie

Producto certificado por: **CE**



CARACTERÍSTICAS

| Modelo | MSAGBU-07HRFN8-QRD1GW(GA) | MSAGBU-09HRFN8-QRD1GW(GA)-I | MSAGBU-12HRFN8-QRD1GW(GA)-I | MSAGCU-18HRFN8-QRDOGW-I | MSAGDU-24HRFN8-QRDOGW-I |
|-----------------------|-------------------------------|-------------------------------|-----------------------------|-------------------------------|---------------------------------|
| Capacidad frigorífica | 2,05 kW | 2,64 kW | 3,52 kW | 5,28 kW | 7,03 kW |
| Capacidad calorífica | 2,64 kW | 3,22 kW | 3,81 kW | 5,57 kW | 7,33 kW |
| Caudal de aire | 300/360/510 m ³ /h | 300/360/560 m ³ /h | -/-/630 m ³ /h | 500/600/800 m ³ /h | 610/770/1.090 m ³ /h |
| Presión sonora | 19/22/30/37 dB(A) | 19/22/31/37 dB(A) | 21/22/33/39 dB(A) | -/31/37/41 dB(A) | -/34,5/37/46 dB(A) |
| Alimentación | 220-240 V / 1 / 50 Hz | | | | |
| Cableado comunicación | (3+T)x2,50 mm ² | (3+T)x2,50 mm ² | (3+T)x2,50 mm ² | (3+T)x2,50 mm ² | (3+T)x2,50 mm ² |
| Tuberías frigoríficas | Ø1/4" / Ø3/8" | Ø1/4" / Ø3/8" | Ø1/4" / Ø3/8" | Ø1/4" / Ø1/2" | Ø3/8" / Ø5/8" |

ESQUEMA CONEXIONES

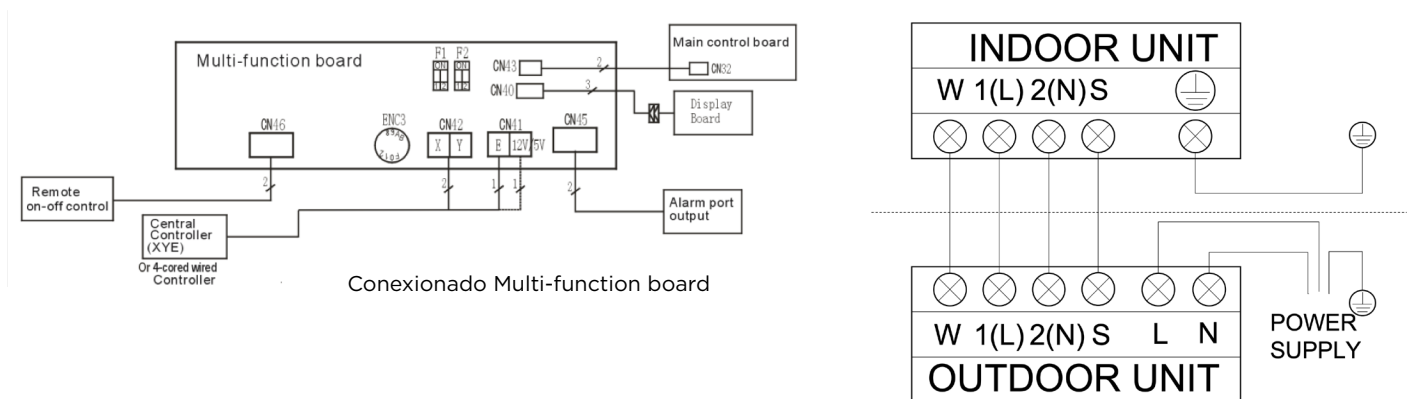

NOTAS:
 (1) Los datos y especificaciones presentes en esta ficha pueden variar sin previo aviso.
 (2) Las imágenes de esta ficha son de carácter orientativo, pudiendo ser diferentes a la máquina final.

DIMENSIONES Y PESO UNIDAD INTERIOR

| Modelo | Peso | W | H | D |
|------------------------------------|----------|----------|--------|--------|
| MSAGBU-07HRFN8-QRD6GW-I | 8,70 kg | 835 mm | 295 mm | 208 mm |
| MSAGBU-09HRFN8-QRD1GW(GA)-I | 8,70 kg | 835 mm | 295 mm | 208 mm |
| MSAGBU-12HRFN8-QRD1GW(GA)-I | 8,70 kg | 835 mm | 295 mm | 208 mm |
| MSAGCU-18HRFN8-QRDOGW-I | 11,20 kg | 969 mm | 320 mm | 241 mm |
| MSAGDU-24HRFN8-QRDOGW-I | 13,60 kg | 1.083 mm | 336 mm | 244 mm |

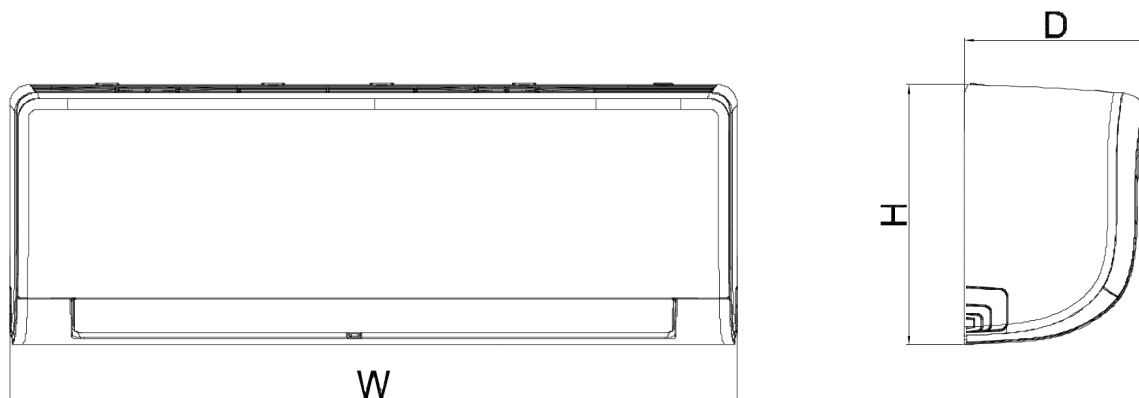

INSTALACIÓN

